

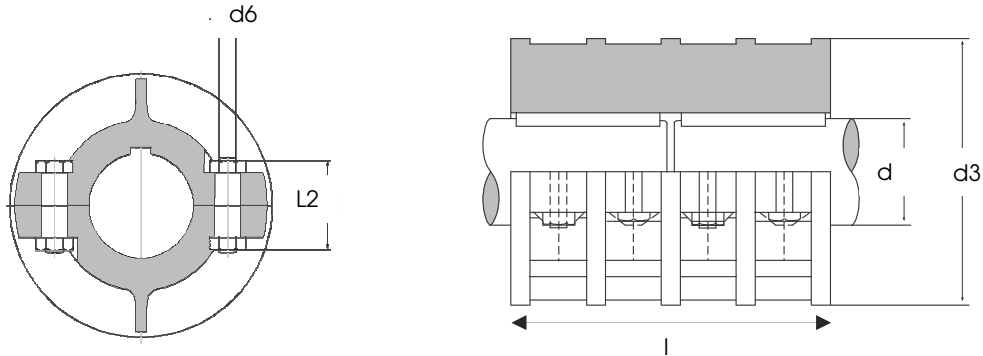

Acoplamiento Rígido Din-115



* Material Fundición GG

Ø d1	PAR NOMINAL	VELOCIDAD	MOMENTO INERCIA	PESO	d3	l	Nº tornillos	d6 x l2
	Nm	rpm max.	J kg/m ²					
20	25	1700	0,00093	1,9	85	100	4	M10 x 30
25	40	1500	0,0034	4,5	100	130	4	M12 x 40
30	60	1500	0,0034	4,2	100	130	4	M12 x 40
35	80	1420	0,0066	6,5	110	160	6	M12 x 50
40	100	1420	0,0065	6,2	110	160	6	M12 x 50
45	125	1350	0,011	8,5	120	190	6	M12 x 50
50	150	1300	0,014	9	130	190	6	M12 x 50
55	500	1200	0,026	13	150	220	6	M12 x 55
60	850	1200	0,025	12,5	150	220	6	M16 x 55
65	1250	1120	0,051	18,5	170	250	6	M16 x 55
70	1700	1120	0,05	17	170	250	6	M16 x 55
75	2000	1060	0,107	28	190	280	8	M16 x 60
80	2500	1060	0,106	27	190	280	8	M16 x 60
90	3800	100	0,203	41	215	310	8	M20 x 75
100	5400	920	0,399	63	250	350	8	M20 x 90
110	7500	920	0,467	70	250	390	8	M24 x 90
120	11000	870	0,771	96	275	430	10	M24 x 90
125	11000	870	0,759	93	275	430	10	M24 x 90
140	15000	800	1,63	160	325	490	10	M27 x 110
160	23000	750	2,84	255	365	560	12	M27 x 110

Acoplamiento Rígido Din-116

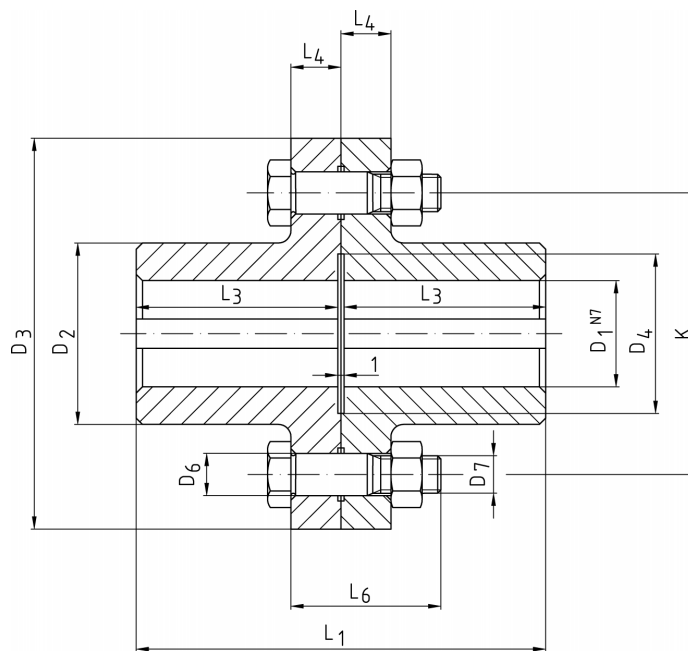

Dimensiones en mm.

D1	D2	D3	D4	D5	D6	K	L1	L2	L3	L4	D7 x L6	Nº Tornillos
25	58	125	40	45	11	90	101	117	50	16	M10 x 45	3
30	58	125	40	45	11	90	101	117	50	16	M10 x 45	3
35	72	140	50	55	11	100	121	141	60	16	M10 x 45	3
40	72	140	50	55	11	100	121	141	60	16	M10 x 45	3
45	95	160	60	65	11	125	141	169	70	18	M10 x 50	3
50	95	160	60	65	11	125	141	169	70	18	M10 x 50	3
55	110	180	70	75	13	140	171	203	85	18	M12 x 50	4
60	110	180	70	75	13	140	171	203	85	18	M12 x 50	4
70	130	200	80	85	13	160	201	233	100	23	M12 x 60	6
80	145	224	90	95	13	180	221	261	110	23	M12 x 60	8
90	164	250	100	105	17	200	241	281	120	30	M16 x 80	8
100	180	280	110	120	17	224	261	301	130	30	M16 x 80	8
110	200	300	120	130	17	250	281	329	140	33	M16 x 85	8
120	225	335	135	145	17	280	311	359	155	33	M16 x 85	10
125	225	335	135	145	17	280	311	359	155	33	M16 x 85	10
140	250	375	150	160	21	310	341	397	170	40	M20 x 100	10
160	290	425	240	180	25	350	401	457	200	40	M24 x 110	10
180	325	450	265	212	25	380	451	507	225	45	M24 x 120	12
200	360	500	290	232	25	420	501	557	250	45	M24 x 120	16
220	400	560	310	252	32	470	541	597	270	52	M30 x 140	14
250	450	630	390	282	32	540	601	657	300	52	M30 x 140	16